



## Power Supply & Charger Technology

### Magnetic Amplifier

Magnetic amplifiers are AC regulators using transformer technology to control power supply output. They work by varying magnetic core saturation that changes the AC reactance of a coil.

The reactance of the AC coil in the reactor (magnetic amplifier) is controlled by a DC winding. When a DC current is passed through this winding the core saturates and the reactance of the AC coil is decreased and the current through the coil goes up. The reactor can be placed in the primary or secondary circuits. In the La Marche chargers the primary is preferred. The input to output isolation is good and easily controlled because of the physical separation between the AC and DC coil on the reactor.

The reactor is placed in series with the primary of the power transformer in the La Marche magnetic amplifier units. When a transistor control is added to the DC coil of the reactor the primary voltage of the power transformer can be precisely regulated to produce voltage and current control of the unit's output.

The nature of the primary magnetic amplifier is inductive. This produces input power factors of about 0.7 for single phase inputs and 0.8 for three phase inputs at rated output in mag-amp designs. The input current harmonic distortion is typically less than 10% and efficiencies run 0.7 for single phase inputs and 0.85 for three phase inputs.

The transformer regulator is very tolerant of AC input spikes and surges, hence the reliability of the design is excellent. This design provides output voltage and current adjustability, a wide input voltage frequency range, good line and load regulation (typically 1%) and convection cooling.

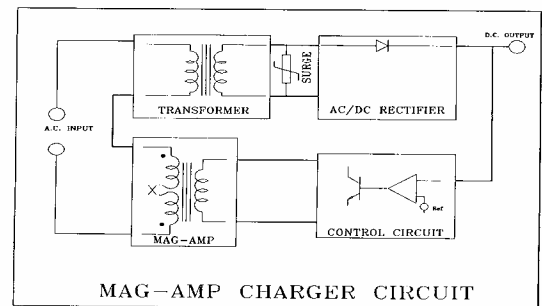

There is no electromagnetic interference generated because it is a linear regulator. The magnetics used in all La Marche products are rated for class H (180 deg. C.) to operate under extreme conditions.

La Marche manufactures the magnetic amplifier in sizes from a few amps to hundreds of amps in 12V to 130V outputs.

La Marche models that utilize magnetic amplifier technology are A40/A40F, A41/A41F, A46/A46F, A48, E12, and A12B.