



## Power Supply & Charger Technology

### Controlled Ferroresonant

The controlled ferroresonant technology utilizes a special power transformer that employs a secondary tank circuit. The primary and secondary of this transformer are magnetically coupled through magnetic shunts. The amount of steel and air gap of these shunts controls the amount of magnetic coupling between the primary and secondary providing an inherent output current limiting.

The secondary of the ferroresonant transformer consists of a tank circuit that is resonated by a high voltage winding and capacitors. This tank circuit keeps the magnetic flux of the secondary in saturation. The effect of the saturated secondary is inherent voltage regulation (an open feedback loop regulator) and loads on the secondary are not linearly reflected back to primary. The primary presents an essentially resistive load to AC line (the power factor is greater than 0.9 for ferroresonant designs).

The ferroresonant power transformer can be controlled by varying voltage on the secondary tank circuit winding. This is done by electronically switching a choke across a portion of this winding using a bi-directional AC switch such as a triac or back to back SCR's. It is only necessary to control about 20% of the output power at this point in the circuit and the control power which circulates around the resonant tank is so small that it actually is lost as heat. The control is therefore efficient and output voltage regulation of 1/2% can be achieved with electronic output current limit in addition to the inherent magnetic current limit of the power transformer.

The characteristics of a saturated secondary and physical separation between the primary and secondary windings in the power transformer design also provide excellent attenuation to incoming transient voltages that may be present on the AC line. Metal Oxide Varistors are used in the La Marche ferroresonant product lines to provide additional protection for sensitive components on the DC side of the charger.

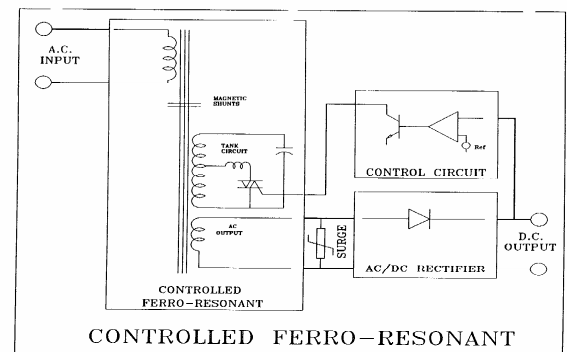

The typical efficiency of ferroresonant units with single phase AC input is 75% and is approximately 85% for three phase inputs. The power factors for either input are typically over 0.9. Power factors that approach 1.0 usually indicate low input harmonic distortion. Although the power factor does not affect efficiencies, higher power factors lower the AC input current requirements.

La Marche manufactures the controlled Ferro resonant in sizes from a few amps to hundreds of amps in 24V to 130V outputs.

La Marche Models that utilize Ferro technology are A36D, TPSD and A85M.