



Model shown: A75R-20-12V-AB1

SCR Railroad Applications

The La Marche model A75R series uses proven SCR charging technology and is developed specifically for the railroad market. It is typically used for signaling, highway crossing and motion detection systems where the battery is cycled frequently.

This filtered unit is designed and built to charge VRLA, Flooded Lead Acid and Nickel Cadmium batteries. Some of the features that make this product unique are remote shutdown, lightning protection and charger failure contacts to name a few. Remote shutdown allows you to place the charger offline for battery testing purposes.

The A75R series is equipped with AAR style hardware on the input and output connections. Temperature compensation is standard to increase the longevity of the batteries and charger. The unit is convection cooled and the components are designed to achieve MTBF in excess of 100,000 hours.

Standard Features

- Microprocessor Controlled SCR Charging Technology
- Single Phase AC Input 120/240V, 50/60Hz
- Automatic AC Input Voltage Compensation $\pm 10\%$
- Complete Isolation from AC to DC
- Lightning Protection
- Temperature Compensation with Enable/Disable Switch
- DC Analog Ammeter and Digital Voltmeter
- Adjustable Current Limit from 50% to 105%
- Filtered Output for VRLA Batteries
- Remote Shutdown
- Form "C" Contact for Charger Failure
- Meets AREMA specifications
- Meets ANSI C62-41
- 3-Year Warranty

Model Number	DC Output				AC Input Current Draw @ 100% (load)	Overall Dimensions W x D x H	Net Weight*	
	Amps	Volts (Nominal)	Battery Cells				lbs	kgs
			Lead Acid	Ni-Cad				
A75R-10-12V-AB1	10	12	5-8	8-12	5.8 amps at 120 VAC 2.9 amps at 240 VAC	12" x 10" x 9" 305 x 254 x 228mm	34	15.5
A75R-20-12V-AB1	20	12	5-8	8-12	8 amps at 120 VAC 4 amps at 240 VAC	12" x 10" x 9" 305 x 254 x 228mm	37	16.8
A75R-40-12V-AB1	40	12	5-8	8-12	15 amps at 120 VAC 8 amps at 240 VAC	14" x 12" x 12" 356 x 305 x 305mm	58	26.4
A75R-30-24V-AB1	30	24	10-16	16-24	22 amps at 120 VAC 11 amps at 240 VAC	14" x 12" x 12" 356 x 3305 x 305mm	76	34.5

*Weight does not include shipping packaging

Charger Specifications

<ul style="list-style-type: none"> • AC Input Dual Input 120/240 VAC ±10% Single Phase 50/60 Hz • Line Regulation ±10% • Load Regulation <±0.5% • Input Protection Fuse with surge protection • Output Current Limit Factory set at 100%, adjustable from 50-105% • Output Protection DC breaker or fuse with surge protection • Meters DC Output Digital Voltmeter (1%) DC Output Analog Ammeter (3%) • LED Indicators Current Limit Temperature Compensation Disable AC On Nickel Cadmium Lead Acid Charger Fail • Environmental Operating: 0° to 50°C (32° to 122°F) (Derated up to 70°) Storage: -40° to 85°C (-40° to 185°F) Relative Humidity: 0 to 95% non condensing

<ul style="list-style-type: none"> • DC Output 12 Volts @ 10 Amps, 20 Amps and 40 Amps Lead Acid: 5L, 6L, 7L and 8L Ni-Cad: 8NC, 9NC, 10NC, 11NC, 12NC 24 Volts @ 30 Amps Lead Acid: 10L, 12L, 14L and 16L Ni-Cad: 16NC, 18NC, 20NC, 22NC, 24NC • Adjustable Voltage Range (per cell) Lead-Acid Cells: 2.15 VDC to 2.35 VDC Nickel-Cadmium: 1.39 VDC to 1.49 VDC • Mounting The enclosures can be wall or shelf mounted • Cable Entry Top • Finish Powder coat finish (RAL 7032) • Standards Meets AREMA specifications Meets ANSI C62-41 • Optional External Temperature Compensation Probe
--

Model Number Nomenclature

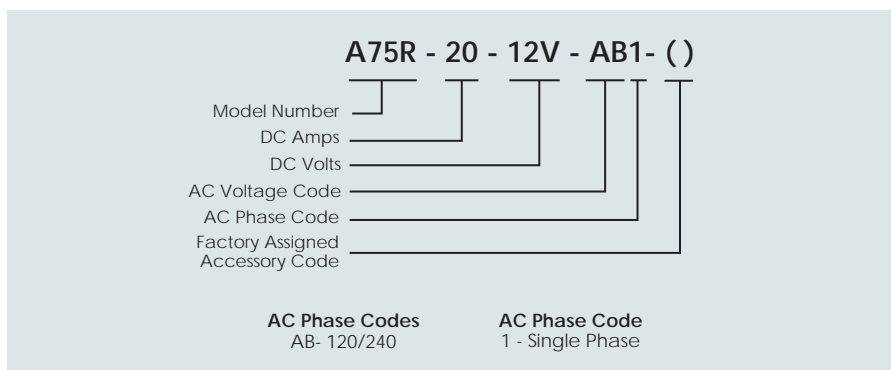

Ordering Information

When ordering, please specify:

- La Marche Model Number
- Input Voltage
- Number of Battery Cells
- A.H. Capacity of Battery
- Allowable Recharge Time from Full Discharge (where applicable)